

CASE SEALER / TAPE FLOOR PLAN

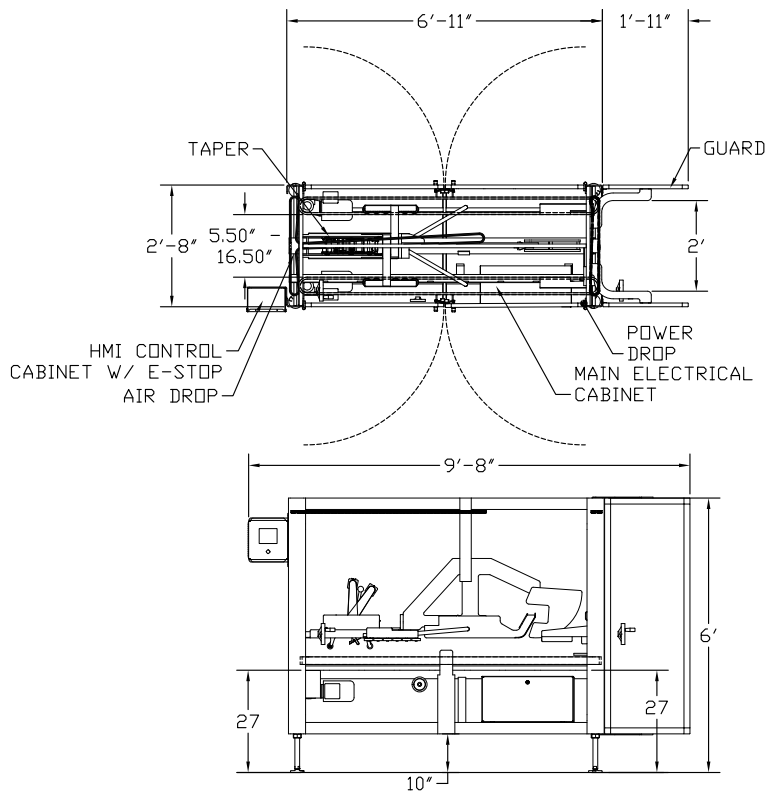

MACHINE SPECIFICATIONS	
MACHINE VOLTAGE	480V-3PH-60HZ
EST AMP LOAD	1.7 AMPS @ 480V
MAIN DISCONNECT	30 AMP FUSED 15 AMP
EST GLUE AMP LOAD	XX AMPS @ 480V
GLUE DISCONNECT	XX AMP FUSED XX AMP
EST AIR USE	TBD SCFM @ 90PSI

NOTE - PRELIMINARY FLOOR PLAN FOR ORIENTATION OF BASE PRICE MACHINE ONLY, DIMENSIONS ARE SUBJECT TO CHANGE ACCORDING TO DESIGN REQUIREMENTS AND OPTIONS PURCHASED

REV.	DATE	REVISED BY	CHANGE DESCRIPTION	REQUESTED BY	APPROVED BY
A	5/30/2018	BLP	RELEASED FOR SALES	AF	AF
DRAWING NAME:			TAPE CASE SEALER FLOOR PLAN		
INSITE PACKAGING AUTOMATION					
DRAWN BY:	CREATION DATE:	SCALE:	PDM I.D.:	SHEET:	
BLP	05/30/2018	1:24		1 OF 1	
PROJECT NO:	DWG SZ:	DRAWING NO:			
MXXXXXX	C	9616390			